

Mining Truck

T 284

Gross Vehicle Weight (GVW):
600 tonnes / 661 tons

Nominal Payload:
363 tonnes / 400 tons

Empty Vehicle Weight (EVW):
237 tonnes / 261 tons



LIEBHERR

T 284

Gross Vehicle Weight (GVW):

600 tonnes/661 tons

Nominal Payload:

363 tonnes/400 tons

Empty Vehicle Weight (EVW):

237 tonnes/261 tons



Productivity

Working Harder and Faster



Efficiency

Moving More for Less





Reliability

Ready to Work
When You Need It



Customer Service

Worldclass Support,
Everywhere, Every Day



Safety

Protecting Your Most
Important Assets



Environment

Mining Responsibly





Productivity



Working Harder and Faster

Intelligent design allows Liebherr ultra class haul trucks to move more tons per hour by maximizing payload and minimizing cycle times.

Speed On Grade

Largest Payload

Ultra class trucks have proven to be a more productive means of moving material. As the designer and manufacturer of the first 400 ton (363 t) mining truck, Liebherr has been at the forefront of this successful industry solution. By hauling more per cycle, the T 284 allows customers to maximize the return on their investment and to meet production targets with fewer trucks, or in less time.

Unmatched Performance

The combination of the efficient Litronic Plus AC drive system, a high power (up to 3,000 kW / 4,023 HP) engine, and low gross vehicle weight leads to fast haul cycle times with higher speeds on grade, when compared to other trucks in its class.

Flexible Engine Options

The T 284 supports multiple engine options with power ratings up to 3,000 kW (4,023 HP). With application-specific recommendations from Liebherr, customers are able to select the engine that will allow the truck to meet productivity targets while minimizing fuel consumption.

Operator Friendliness

Liebherr is committed to designing mining trucks that operators want to drive. The T 284 fulfills this commitment and promotes driver efficiency with superior comfort, safety, acceleration and handling.



High Horse Power Engine

- MTU 20V4000 C23 Tier 2
- 3,000 kW / 4,023 HP
- Speed on grade

Lightweight Design

- Liebherr's trademark low EVW (Empty Vehicle Weight) is achieved by combining an electric drive system and lightweight frame
- Hauling the largest available payload with a lighter truck maximizes customer productivity

Multiple Loading Tools

- Designed to match large electric shovels and wheel loaders like all other Liebherr mining trucks
- Suited for both the Liebherr R 9800 and the R 996 B hydraulic excavator

Efficiency



Moving More for Less

Efficiency is a key ingredient for a successful mining operation. Liebherr mining equipment enables customers to enjoy unrivaled performance while reducing their cost per ton.

Reducing Cost Per Ton

Litronic Plus Technology

Developed and built by Liebherr, the proven Litronic Plus drive system determines the most effective way to extract power from the diesel engine. Efficient loading of the engine is critical to minimize fuel consumption and maximize performance.

Long Life Components

Components are built to perform in the most extreme mining conditions in order to allow more time between overhauls and to reach their maximum operational life.

Intelligent Power Usage

Engine power usage is refined by running auxiliary components such as pumps, fans and motors only when needed. Fuel is conserved when the engine is idling and more power is available to accelerate the truck and climb grades when necessary.



Wheel Motors

- T 284 AC induction motors efficiently convert electrical power into mechanical torque
- Fewer electrical losses translate into higher rimpull forces for faster cycle times and increased fuel economy

Engine / Fuel System

- High reliable engine options
- Safe and energy efficient
- Reduced fuel consumption

Litronic Plus AC Drive System

- Liebherr's efficient drive system with high power to ground ratios enables fast acceleration
- High speeds on grade for increased productivity



Reliability



Ready to Work When You Need It

Liebherr draws upon a wealth of experience while incorporating new technologies into its products to provide customers with high quality equipment and services.

Quality: the Liebherr Trademark

Experience

Millions of operating hours and years of design experience have come together to create the Liebherr T 284. With a history of products with proven reliability in the harshest mining environments, Liebherr customers can count on consistent performance.

Diagnostics

An integrated electronic system monitors, records, and outputs vital truck health and performance data. Data is stored and available for download to perform detailed analysis. This system supports predictive maintenance strategies to minimize unscheduled downtime.

Truck data is readily available to fleet dispatch or monitoring systems through a dedicated port using open communication protocols. This allows customers the flexibility to choose systems which support their maintenance, operations, and business process requirements.

Advanced Engineering Tools

Liebherr's structural design process includes advanced software tools to ensure the T 284 will perform reliably, even under the most demanding operating conditions. Some of the tools include:

- Multi-body Dynamic Simulations
- 3D modeling
- Finite Element Analysis (FEA)
- Structural Fatigue Life prediction software

Special Environment Kits

Due to extreme environmental differences for Customers, Liebherr offers an array of special environment kits. These kits guarantee that the T 284 will be fit for any working conditions. Some of these are:

- Sound Attenuation Kit – minimizes noise produced by the fan, engine, dynamic braking and exhaust systems
- High Altitude Kit – supports equipment in low oxygen up to 5,000 m
- Cold Weather Package – enables the machine to operate efficiently in extreme cold climate conditions (temperatures down to -50 °C)



Lightweight Frame

- The T 284 frame is designed according to international weld fatigue guidelines
- Fabricated according to American Welding Society standards
- The steel structure includes cast components in strategic areas and hollow box rails with fully welded internal stiffeners – the most durable, lightweight frame available

Integrated Dash Display

- The monitoring system includes an onboard 30.7 cm (12.1") touch-screen display
- Intuitive menus and user-friendly screens provide operators and technicians with realtime truck information
- Password protected diagnostic screens display live data such as temperatures and pressures for detailed troubleshooting

Liebherr Mining Data System

- Machine Health Monitoring and Diagnostics aid machine operators in avoiding catastrophic component failures, improve machine troubleshooting and lead to more transparent machine maintenance and repair planning
- Machine Performance Monitoring provides instantaneous or historic productivity, cycle time or fuel consumption statistics
- Application Monitoring aids in Misuse Detection and Avoidance to avoid use of equipment outside of operational parameters



Customer Service



Worldclass Support, Everywhere, Every Day

Liebherr is a committed full life-cycle service organization, as well as a global parts warehousing and remanufacturing network.

Product Support

Liebherr provides tailored customer service to best suit our customers' individual requirements. Our global network, long industry expertise, and strong relationships allow us to better provide integral support to our customers.

There are different levels of product support available:

- Assembly
- Maintenance advice
- Troubleshooting assistance
- Technical expertise

Product support personnel work with customers from the assembly of a truck throughout its operating life.

Product Upgrade Programs

Liebherr offers component and system upgrades as advances in technology, innovation in design, and manufacturing improvements become available. The product upgrades use new knowledge to improve performance, reliability and safety, giving the customer added benefits to their existing fleet.

Parts Support and Logistics

Liebherr forecasts parts requirements on a global basis and monitors inventories to meet customers' needs. Liebherr offers a 24/7 on-call service to ensure prompt response.



Extended Component Life

- Liebherr designed Service Exchange Units enable customers to minimize the total lifecycle cost of owning and operating a Liebherr mining truck or excavator
- Maintains peak productivity and reliability
- All exchange components are built to OEM standards, offering as-new warranties

Advanced Training Capabilities

- The Liebherr Mining Training System provides operator and field services technicians with world-class training
- Simulator based operator training
- Basic and advanced service technician training
- Hands-on troubleshooting training

Excellent Serviceability

- Designed for easy and safe serviceability
- Centralized access to all cab electrical connections from the superstructure
- Industry-trained personnel
- Support for customers throughout the equipment life-cycle
- Liebherr's intelligent service and maintenance process captures data which feeds back to our factories to integrate into continuous development



Safety



Protecting Your Most Important Assets

Liebherr designs and builds safety into every piece of mining equipment, and is committed to providing a safe and healthy working environment for the operator and service personnel.

Safety-First Working Conditions

Operator Safety

The T 284 cab is designed to be a safe, comfortable and productive environment for operators. The cab provides maximum visibility and is certified for roll-over and falling-object protection. All Liebherr trucks offer at least two safety routes from the cab to the ground.

Operational Safety

In order to maintain a safe working environment, the T 284 offers the following features.

- Payload overload warnings
- Anti-roll back feature active in forward and reverse
- Certified steering and braking accumulators
- High visibility LED running and service lights
- Engine stop buttons in cab and at ground level

Service Personnel Safety

Liebherr mining trucks are equipped with ladders and platforms that allow easy engine access. The low working heights of maintenance areas provide safe and efficient service access.

- Access to the engine and alternator from both sides of the chassis
- Ground level filling points for fuel, hydraulic oil, grease and coolant
- Hydraulic filters and battery isolation box accessible from ground level
- Dual access into axle box for maintenance and inspection
- Tie-offs for safety harnesses
- Centralized access to all cab electrical connections from the superstructure floor



Stability and Control

- Advanced Traction Control System with fourwheel speed sensing capability
- Torque is automatically adjusted to the rear wheels to maximize traction when cornering, accelerating from a standstill, or traveling down wet or icy roads
- Traction Control System developed by Liebherr exclusively for mining trucks enables operators to consistently maintain steering control and truck stability

Operator Assist Features (Optional)

- Detection system alerts the operator when an object is in close proximity to the stationary truck
- Fatigue system provides real-time monitoring of the operator for fatigue and distraction events while the truck is in motion

Operator Safety

- The ergonomic design of the cab creates a safe, comfortable and productive environment for operators
- Maximum visibility and certified roll-over and falling-object protection
- Two safety routes from the cab to the ground



Environment



Mining Responsibly

In order to minimize environmental impact, Liebherr designs and builds mining equipment with the smallest possible environmental footprint.

Minimized Impact on the Environment

Low Emissions

By partnering with the leading providers of high speed diesel engines, Liebherr is able to offer engine options for the T 284 with the latest emission technology to satisfy US EPA emissions requirements.

Fuel Efficiency

Liebherr's Litronic Plus drive system paired with the latest engine technology provides excellent fuel economy. Lowering the fuel consumption of the truck fleet can significantly reduce the carbon footprint of the entire operation.

Environmentally Sustainable Mining

Component Exchange

The Liebherr exchange program aims to extend component life-cycles and reduce unplanned maintenance by having condition-based replacement parts. Liebherr also reduces waste by overhauling components using original core parts, contributing to environmental sustainability through substantial material and energy savings.

Sound Solutions

Factory engineered Sound Attenuation packages featuring a low speed engine fan, enclosed engine bay, and custom mufflers drastically reduce the truck noise emissions. Day or night, this ultra quiet truck gives customers the flexibility to run their operations without disturbing nearby residential areas.

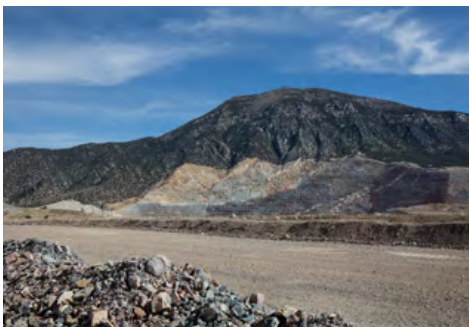

Fewer Carbon-based Consumables

- Uses fewer consumables compared to similar trucks in its class
- Requires less service time
- Reduces the costs of handling and disposing of waste

Longer Tire Life

- Minimized lateral tire force by keeping the double A-Arm front suspensions in contact with the ground over uneven roads or while turning the truck
- Reduced wear when the truck is driving loaded

Sustainable Manufacturing Process

- With an ever-present green focus, Liebherr contributes to the sustainable development
- Conducting systematic risk analysis for new materials qualification
- Promoting recovery-waste management to keep non-recyclables to a minimum

Technical Data

Engine

Model	MTU 20V4000 C23 Tier 2 ¹⁾
Gross horsepower @ 1,800 rpm²⁾	3,000 kW/4,023 HP ³⁾
No. of cylinders	20
Displacement	95.4 l/5,822 in ³
Wet weight	11,769 kg/25,946 lb
Crankcase	335 l/88 gal
Cooling system	1,060 l/280 gal

¹⁾ Standard engine setting is USA/EPA Tier 2 compliant in emission-optimized (EO) mode. Fuel-optimized (FO) mode is optional for non-emission regulated countries.

²⁾ Gross power definition according to ISO 3046 (ratings also correspond to SAE J 1995 standard conditions).

³⁾ Optional 2,800 kW/3,750 HP engine power setting. Consult factory for additional reduced engine power settings.

Model	MTU 20V4000 C22 Tier 1 ¹⁾
Gross horsepower @ 1,800 rpm²⁾	2,720 kW/3,648 HP
No. of cylinders	20
Displacement	90 l/5,490 in ³
Wet weight	10,480 kg/23,100 lb
Crankcase	390 l/103 gal
Cooling system	870 l/230 gal

¹⁾ Standard engine setting is USA/EPA Tier 1 compliant.

²⁾ Gross power definition according to ISO 3046 (ratings also correspond to SAE J 1995 standard conditions).

Model	MTU 20V4000 C65 Tier 4f
Gross horsepower @ 1,800 rpm	3,000 kW/4,023 HP
No. of cylinders	20
Displacement	95.4 l/5,822 in ³
Wet weight	12,554 kg/27,677 lb
Crankcase	335 l/88 gal
Cooling system	1,018 l/269 gal

Model	Cummins QSK 78
Gross horsepower @ 1,900 rpm¹⁾	2,610 kW/3,500 HP
No. of cylinders	18
Displacement	78 l/4,735 in ³
Wet weight	11,300 kg/24,912 lb
Crankcase	295 l/78 gal
Cooling system	721 l/191 gal

¹⁾ Gross power definition according to SAE J 1995 standard conditions.

Electric Drive System

Control system	Liebherr Litronic Plus AC drive system with IGBT technology
Control box	Liquid cooled power components, pressurized cabinet
Main alternator	AC brushless, direct drive, forced air cooling
Wheel motors	Litronic Plus AC induction motors, forced air cooling
Maximum speed¹⁾	54 km/h/34 mph (with 43.7:1 gear ratio) 64 km/h/40 mph (with 37.33:1 gear ratio) 45 km/h/28 mph (with 53.33:1 gear ratio)
Cooling system	variable speed AC motor with twin impeller radial cooling fans

¹⁾ Consult factory for proper selection of gear ratio based on site requirements.

Braking Systems

Electric dynamic braking, forced air over quiet stainless steel grid resistors with dry disc service and secondary braking system.

Electric dynamic braking	max. 4,500 kW/6,035 HP full dynamic braking down to zero. Single pedal automatic brake blending with service brakes below 1 km/h
Dynamic braking speed control	operator adjustable, automatically limits truck speed on downhill grade when set
Adjustable speed limits	Automatic speed limits for empty and loaded truck adjustable for site requirements
Traction control	Litronic Plus traction control system. Computer controlled in propel and dynamic braking, forward and reverse, all-wheel speed sensing
Service brakes front	single disc, wheel speed, five calipers per wheel
Service brakes rear	dual discs per side, one caliper per disc, armature speed
Hydraulic accumulators	1 x 7.6 l (2 gal), x 3.8 l (1 gal), 1 x 26.5 l (7 gal) accumulators (4 in total), separate isolated accumulator for front and rear axle (piston type)
Park brakes	spring applied, pressure released, one caliper per each rear disc
Filtration	cleanliness level ISO 15/13/11

Steering

Ackerman center point lever system, full hydraulic power steering with accumulator safety backup. Isolated from dump hydraulic system. Two double-acting hydraulic cylinders.

Hydraulic accumulator	170 l/46 gal (piston type)
Filtration	cleanliness level ISO 15/13/11
Turning radius (ISO 7457) – tire centerline	17.2 m/56'5"
Vehicle clearance radius	19.95 m/65'5"

Dump System

Two double-stage, double-acting hoist cylinders with inter-stage and end cushioning in both directions. Electronic joystick with integrated engine high-idle switch and full modulating control in both extend and retract.

Dump angle	49° (45° with optional kick-out switch)
Cycle times	56 secs
Remote dump	quick disconnects for external power dumping (buddy dump) accessible from ground level
Filtration	high pressure and return line filtration. Cleanliness level ISO 18/16/13



Suspension System

Front	double A-arm with inclined king pin pivot, spindle and nitrogen over oil suspensions with integral damping
Rear	three bar linkage comprised of triangular upper link plus two bottom drag links and nitrogen over oil suspensions with integral damping



Tires

Tires	56/80 R63 59/80 R63 ¹⁾
--------------	--------------------------------------

¹⁾ 44" rims only except Bridgestone which can operate on 41" rims as well



Frame

Design	closed box structure with multiple torque tube cross members, internal stiffeners and integrated front bumper. High strength steel castings are used in high stress areas
Welding	frame girders welded inside and out with ultrasonic inspection aligned with AWS D1.1



Cab

Deluxe cab with integrated ROPS, FOPS, and double wall design for optimum insulation. Fully adjustable air suspension operator seat with double lumbar support and full-size second seat for training requirements. Operator comfort controls include a tilt steering wheel, heater, defroster and standard AC. Real-time vital truck information is easily displayed to the operator and also recorded for download.



Weights

Payload	363 t/400 ton
Gross vehicle weight (GVW)	600 t/661 ton
Chassis weight¹⁾	198 t/218 ton
Body weight	custom for each mine
Weight distribution	empty – front 50% / rear 50% loaded – front 33% / rear 67%
Empty vehicle weight	237 t/261 ton

¹⁾ Standard truck (less options), 100% fluids (fuel tanks, hydraulic tank, gears, suspensions, crankcase, coolant, grease and charged accumulators)



Fluid Capacities

Standard fuel tank	5,351 l/1,414 gal
Hydraulic dump circuit	
Tank	1,302 l/344 gal
System	1,514 l/400 gal
Hydraulic brake and steering	
Tank	924 l/244 gal
System	1,060 l/280 gal
Planetary gear sets, each (2)	280 l/74 gal
Front wheels, each (2)	60 l/16 gal
Grease tank	54 kg/120 lb



Body

Body sizes are custom designed to fit Customer requirements and specific applications. Please contact factory for options.



Sound

Interior cab noise level (per ISO 6394:2008)	75 dB(A) sound pressure
Exterior noise emission (per ISO 6393:2008)	126 dB(A) sound power

Dimensions

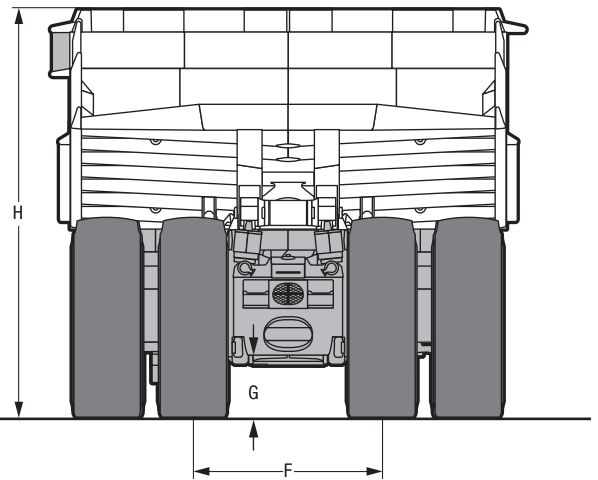
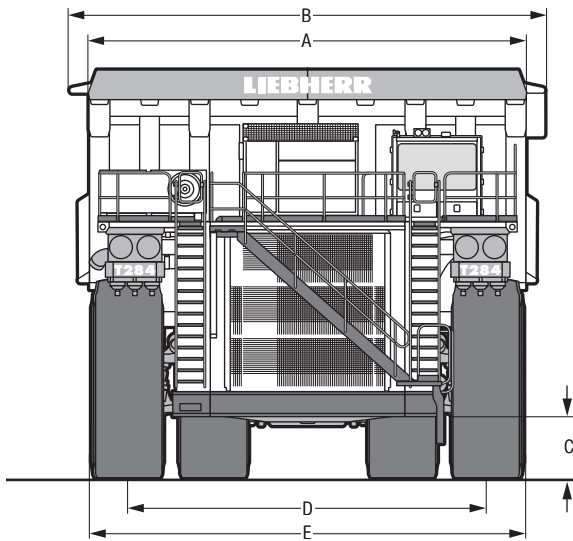
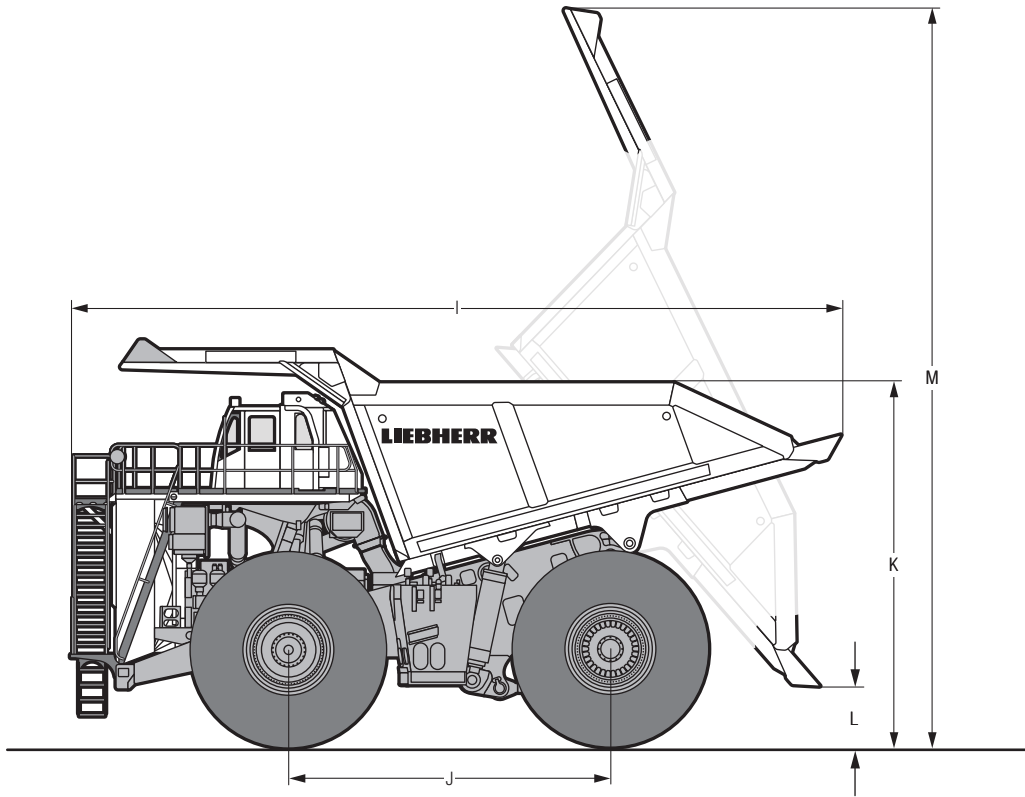

	mm/ft in
A Outside body width	8,891/29' 2"
B Overall truck width	9,679/31' 8"
C Bumper ground clearance	1,240/ 4'
D Centerline front tire width	7,290/24'
E Overall tire width	8,715/28' 7"
F Centerline rear dual width	3,909/12'10"
G Rear axle clearance	1,057/ 3' 6"

	mm/ft in
H Front canopy height	8,294/27'2"
I Overall truck length	15,690/51'5"
J Wheelbase	6,553/21'5"
K Loading height	7,425/24'4"
L Dump clearance	1,249/ 4'1"
M Body raised height	15,050/49'4"

Performance Curves

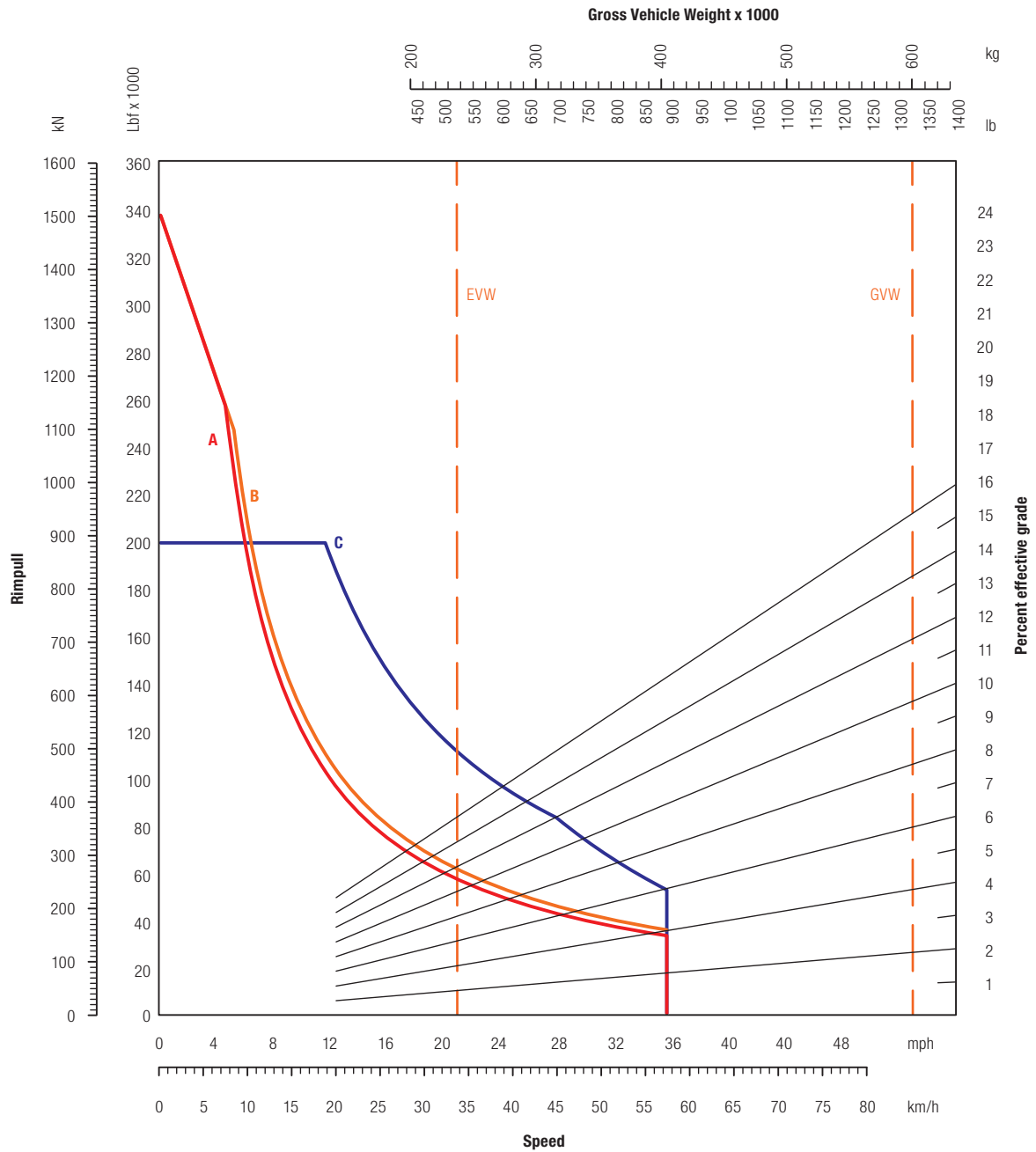

Performance Chart Parameters

Gross power	2,800 kW / 3,755 HP (A) 3,000 kW / 4,023 HP (B)
Net power	2,614 kW / 3,505 HP (A) 2,814 kW / 3,774 HP (B)
Tire size	59.80 R63
Gear ratio	43.7 to 1
Reference curves	A: Propulsion 2,800 kW / 3,755 HP B: Propulsion 3,000 kW / 4,023 HP C: Dynamic Braking (Retard)

Note: The propulsion curve is calculated using net horsepower, therefore site specific and climatic variables will have an effect on the parasitic loss estimations.

Loading Charts

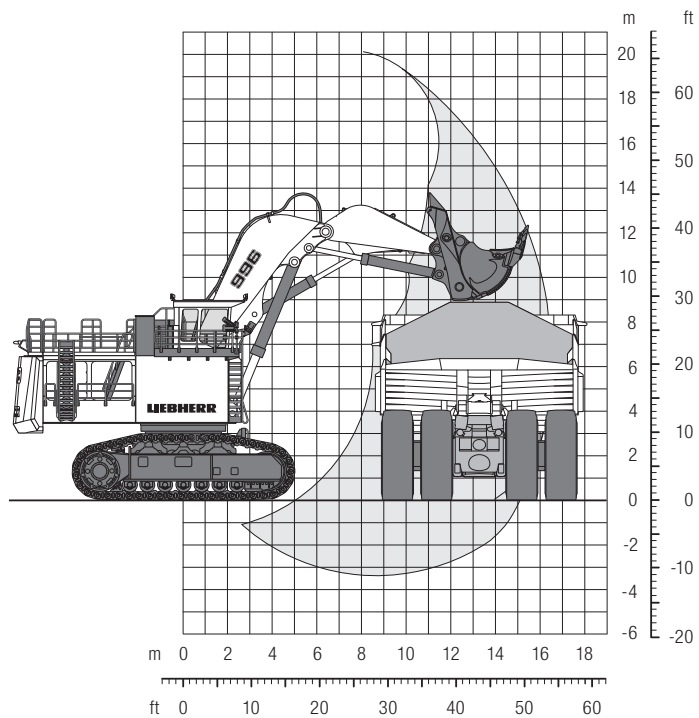

T 284 Mining Truck

loaded by the Liebherr R 996 B hydraulic excavator in face shovel configuration

Maximum dump height	12.9 m / 42'3"
Truck loading height	7.4 m / 24'4"
Passes to fill	6 passes

(given a 1.8 t/m³ density at 95% bucket fill factor)

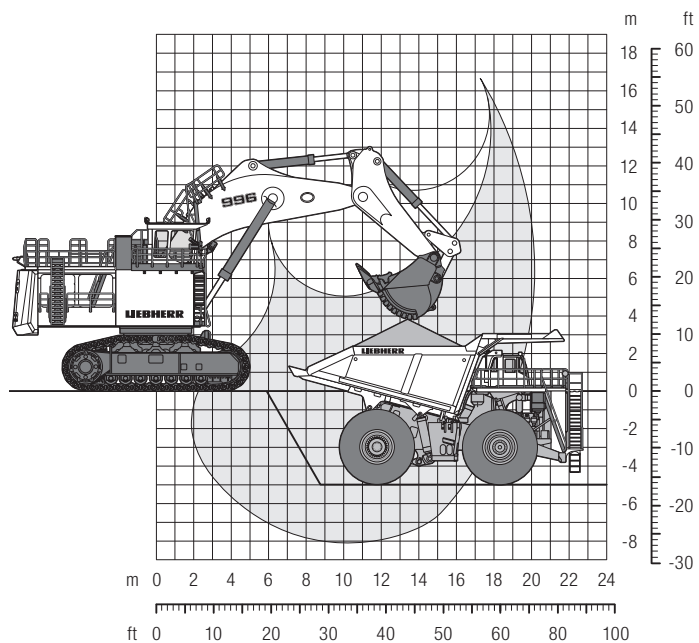

T 284 Mining Truck

loaded by the Liebherr R 996 B hydraulic excavator in backhoe configuration

Maximum dump height	10.7 m / 34'11"
Truck loading height	7.4 m / 24' 4"
Passes to fill	6 passes

(given a 1.8 t/m³ density at 95% bucket fill factor)

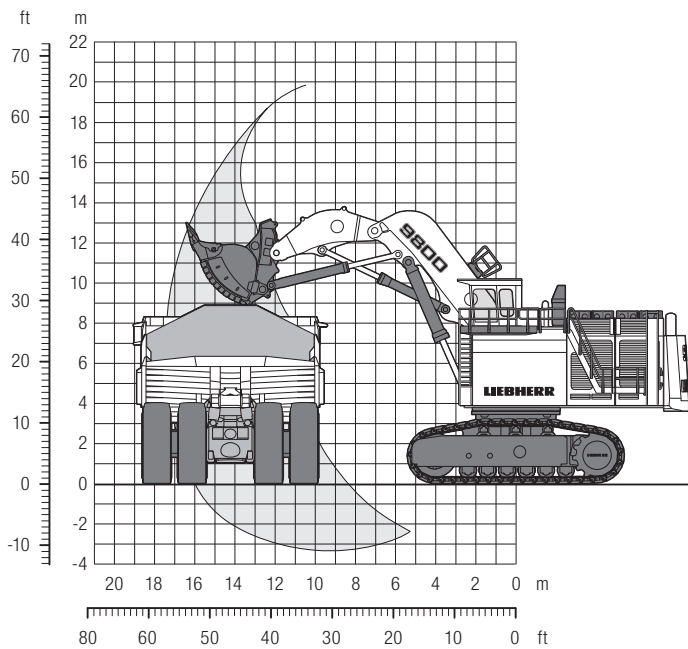

T 284 Mining Truck

loaded by the Liebherr R 9800 hydraulic excavator in face shovel configuration

Maximum dump height	13 m / 42'6"
Truck loading height	7.4 m / 24'4"
Passes to fill	5 passes
(given a 1.8 t/m ³ density at 95% bucket fill factor)	

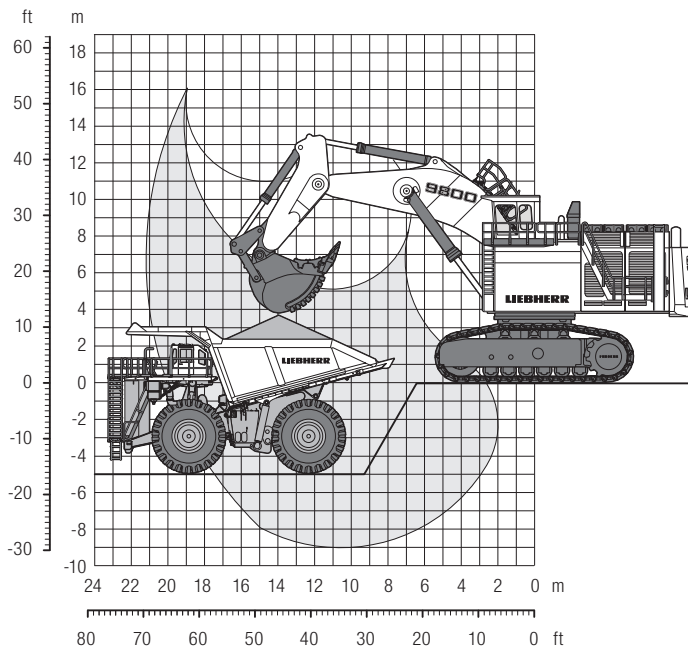

T 284 Mining Truck

loaded by the Liebherr R 9800 hydraulic excavator in backhoe configuration

Maximum dump height	10.9 m / 35'9"
Truck loading height	7.4 m / 24'4"
Passes to fill	5 passes
(given a 1.8 t/m ³ density at 95% bucket fill factor)	

Standard Equipment

Engine

Air cleaner dust ejectors – automatic
Air cleaners – two units with 2 elements per unit with electronic restriction monitoring in cab
Engine “roll over” protection switch
Exhaust – side-mounted mufflers with insulated exhaust pipes
Fan clutch – variable speed, temperature controlled
Fuel/water separator
Multi-point exhaust temperature monitoring system (ETMS)
Oil centrifuge filter
Prelube – pre-start engine oil pressurization to reduce dry engine turnover
Primary and secondary fuel filters
Radiator-Flexible – core with individual field replaceable cooling tubes, flexible core, w/side mounted header tank level gauge
Roll out power module – radiator, engine and main alternator mounted on roll out sub frame
Turbo thermal protection
Starter – electric

24 V Electrical

Batteries – 6 x 12 Volt, (3 series of 2), 1,200 CCA each at –18 °C (0 °F), 1,475 CCA at 0 °C (32 °F)
Battery box lockouts – ground level, battery, propel and starter
Electrical system – 24 VDC with circuit breaker protection
Engine stops – in-cab and ground level

Operator Environment

Climate control – combined heater and air conditioner w/multiple air ducts and filtered air
Cup holder – 2 center console mounted
Diagnostics interface – Ethernet
Display screen – dimmable color touch screen w/operator information and warning
Dual overhead LED dome lights that illuminate when the door is opened
Integrated ROPS (ISO 3471:2008) and FOPS (ISO 3449:2005, Level II)
Mirrors – drivers side (flat), offside (convex) and access ladder (convex)
Power windows – driver and passenger
Pressurized cab – with fan on
Radio ready – wiring, speakers and DIN fitting
Seat belt – high visibility orange 3 point 2 inch wide
Seats – fully adjustable driver and passenger heated seats with air suspension
Speedometer – km/h / mph
Steering wheel – tilting and telescopic with horn and wiper control
Storage shelves and storage compartment located behind seats
Sun visors – 2 windshield sun visors and 1 driver’s door mounted blind
Windows – tempered and tinted glass 6 mm
Windshield – laminated safety glass and tinted 9.5 mm
Wipers – two speed electric and intermittent with self park and dual wiper arms

AC Drive System and Controls

Anti-roll back – in forward and reverse
Brakes – dynamic braking w/automatic hydraulic brake blending and hydraulic service brakes
Gear assembly – Liebherr gears and wheel motors
Gear ratio – 43.7:1
Grid box – resistor grid control system and variable AC grid box blower motor
Litronic Plus control cabinet – IGBT technology, liquid cooled, pressurized, filtered air inlet, ground fault warning and detection
Traction control system with four-wheel speed sensing

Lighting

Access lights – 3 ladder, 1 superstructure
Brake warning lights (cab mounted external) – forward facing dynamic and service brake (LED)
Headlights – 4 x high beam, 4 x low beam (LED)
Reverse lights – 2 x axle box, 1 x driver’s side superstructure (LED)
Service lights – 4 x engine bay, 2 x axle box (LED)
Truck lights – tail, brake, retarder and indicators (LED)

Other

Access ladders – 45° diagonal stair (drivers side access) with two side ladders w/flexible step
Accumulators – certified, 1 steering 170 l (45 gal), 2 brakes 7.6 l (2 gal) (split front and rear brakes)
Axle box – dual entry service access and rear air exhaust
Catwalk – right and left side of engine
Centralized service station – ground level, driver side, with fuel gauge
Color – white / gray
Fall protection – multiple personnel tie off points
Fluid sampling – multi-sampling ports close to component
Grease system – automatic lubrication system
Hydraulic filters – high pressure and return line brake, steering and hoist w/electronic monitoring
LED payload display – 2 x superstructure mounted
Mud flaps – front and rear of hydraulic and fuel tanks
Oil coolers – 1 x hoist system, 2 x final drive, 1 x fuel
Park brake – spring applied pressure release
Recovery system – auxiliary connectors for brake, steering and hoist “buddy system”
Reverse alarm (2)
Rims – bolt on, 2 x double gutter, 4 x single gutter
Rock ejectors – bar type
Service access ladders – right and left engine bay ladders w/cable steps
Shut off valves – brake and steering and hoist w/electronic monitoring
Sight gauges – brake, steering, hoist and radiator tanks and front wheel hub
Towing points – front and rear

Optional Equipment

Additional

Access stair – powered retractable stair to main diagonal stairway
Adjustable access ladders – engine bay
Advanced camera system – four views (off driver side, driver side, reverse, and forward), integrated into dashboard touchscreen
Berm cornering lights (LED) – forward facing, superstructure mounted (DS and ODS)
Blue truck identifier light – grill mounted
Centered dashboard gauge panel in metric or imperial
Centered dashboard gauge panel in metric and imperial
Cold climate – diesel type engine heater, w/automatic control
Color – Liebherr yellow/grey
Dump body – liners, heated, tailgates, rock deflectors
Dump body raise limit – 45° kick out switch
EPA Tier 2 and Tier 4f certifications
Fatigue monitoring system
Fog lights (LED) – 4 x bottom radiator mounted
Gear ratios – 37.33:1 and 53.33:1
Grill illumination light (LED)
Heated dump body ready
Heated mirrors
High altitude package (HAP)
Hill cresting lights (LED) – 2 x top grill mounted
Multiple language decals
Overspeed light – externally mounted blue strobe on top of cab
Park brake off/truck in neutral warning light (LED) – externally mounted on top of cab
Power outlets – 12 VDC and 115 VAC
Reverse light (LED) – off driver's side superstructure
Rock ejectors – chain type
Sound attenuation package
Trolley capable
Undercarriage protection – belly pan and hydraulic tank

Standard and optional equipment are subject to change at manufacturer's discretion. Please contact your local representative for further information.

The Liebherr Group of Companies

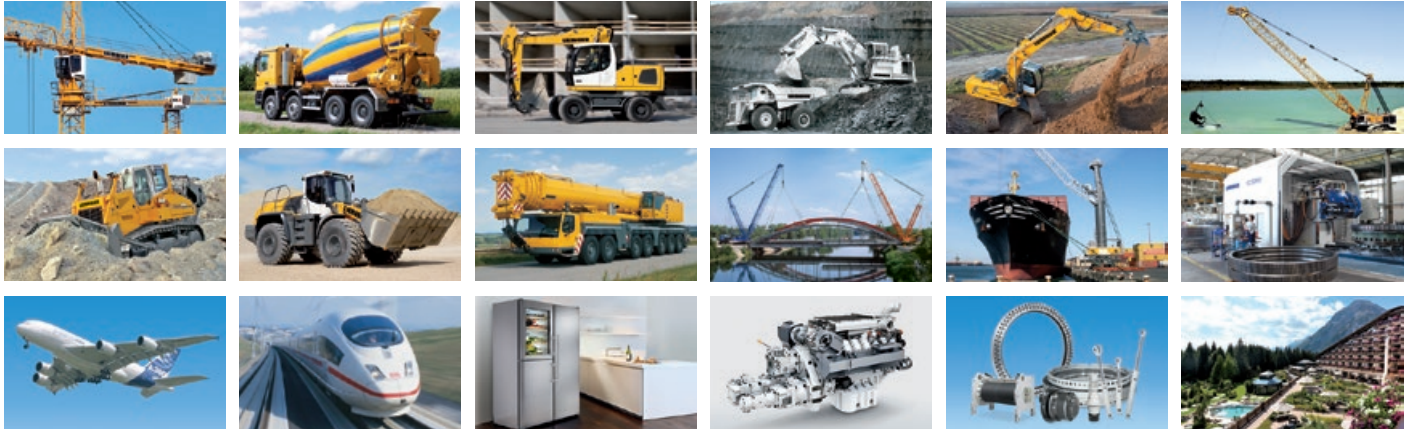

Wide Product Range

The Liebherr Group is one of the largest construction equipment manufacturers in the world. Liebherr's high-value products and services enjoy a high reputation in many other fields. The wide range includes domestic appliances, aerospace and transportation systems, machine tools and maritime cranes.

Exceptional Customer Benefit

Every product line provides a complete range of models in many different versions. With both their technical excellence and acknowledged quality, Liebherr products offer a maximum of customer benefits in practical application.

State-of-the-art Technology

To provide consistent, top quality products, Liebherr attaches great importance to each product area, its components and core technologies. Important modules and components are developed and manufactured in-house, for instance the entire drive and control technology for construction equipment and mining trucks.

Worldwide and Independent

Hans Liebherr founded the Liebherr family company in 1949. Since that time, the enterprise has steadily grown to a group of more than 130 companies with over 41,000 employees located on all continents. The corporate headquarters of the Group is Liebherr-International AG in Bulle, Switzerland. The Liebherr family is the sole owner of the company.

www.liebherr.us