

KOMATSU®

930E-4SE

MAXIMUM GVW
505755 kg 1,115,000 lb

GROSS HORSEPOWER
2611 kW 3,500 HP

930E

ELECTRIC DRIVE TRUCK



Photo may include optional equipment.

930E-4SE ELECTRIC DRIVE TRUCK

SPECIFICATIONS



ENGINE

Make and model Komatsu SSDA18V170
 Fuel Diesel
 Number of cylinders 18
 Operating cycle 4 cycle
 Gross horsepower 2611 kW **3,500 HP** @ 1900 rpm
 Net flywheel power* 2558 kW **3,429 HP** @ 1900 rpm
 Weight (wet) 10100 kg **22,266 lb**

* Net flywheel power is the rated power at the engine flywheel minus the average accessory losses. Accessories include fan and charging alternator.

Power ratings above represent engine performance in accordance with SAE J1995 and J1349 conditions.



ELECTRIC DRIVE

AC CURRENT

Alternator GTA-39
 Dual impeller in-line blower 453 m³/min **16,000 cfm**
 Control AC Torque Control System
 Motorized wheels* GDY106 AC Induction Traction Motors
 Ratio** 32.62:1
 Speed (maximum) 64.5 km/h **40 mph**

* Wheel motor application depends upon gross vehicle weight, haul road grade, haul road length, rolling resistance and other parameters. Komatsu and G.E. must analyze each job condition to assure proper application.

** Optional ratios available.



TIRES AND RIMS

Rock service, tubeless, radial tires

Standard tire* 53/80 R63

Taper Lock

914 mm x 1600 mm x 127 mm **36" x 63" x 5.0"** rim assembly

Rated at 758 kPa **110 psi** cold inflation pressure for rims,
 600 kPa **87 psi** for tires.

* Tires should meet application requirements for tkph/tmph, tread, compound, inflation pressure, ply rating or equivalent, etc.



BODY

All-welded steel flat floor body with horizontal bolsters and full canopy. Eyebrow, rear wheel rock ejectors, body up sling, and rubber mounts on frame are standard. Pivot exhaust heating optional.

Floor sheet 16 mm **0.63"** 1379 MPa **200,000 psi**
 tensile strength steel (two-piece)

Front sheet 9 mm **0.35"** 1379 MPa **200,000 psi**
 tensile strength steel

Side sheet 8 mm **0.31"** 1379 MPa **200,000 psi**
 tensile strength steel

Canopy sheet 5 mm **0.19"** 690 MPa **100,000 psi**
 tensile strength steel

Standard SAE heaped 2:1 211 m³ **276 yd³**

Standard Komatsu body weight 30362 kg **66,936 lb**

* Komatsu must approve all bodies through a Body Application Worksheet.



CAB

Advanced Operator Environment with integral 4-post ROPS/FOPS structure (meets J1040 Apr88), adjustable air suspension seat w/lumbar support and arm rests, passenger seat, maximum R-value insulation, tilt and telescoping steering wheel, electric windshield wipers w/washer, tinted safety glass, power windows, Komatsu Payload Weighing System, 55,000 Btu/hr heater and defroster, 21,600 Btu/hr air conditioning (HFC - 134A refrigerant).



FRAME

Advanced technology, full butt-welded box sectional ladder-type frame with integral ROPS supports, integral front bumper, rear tubular cross members, steel castings at all critical stress transition zones, rugged continuous horsecollar.

Plate material 482.6 MPa **70,000 psi**
 tensile strength steel

Casting material 620.5 MPa **90,000 psi**
 tensile strength steel

Rail width 305 mm **12"**

Rail depth (minimum) 864 mm **34"**

Top and bottom plate thickness 45 mm **1.77"**

Side plate thickness 25 mm **0.98"**

Drive axle mounting Pin and spherical bushing

Drive axle alignment Swing link between frame and axle



BRAKING SYSTEM

Service brakes: oil-cooled, hydraulic-actuated, multiple disc brakes at each wheel. Traction system wheel slip/slide control.

Max. service apply pressure 17237 kPa **2500 psi**

Total friction area per brake 97025 cm² **15,038 in²**

Secondary brakes Automatically applied prior to hydraulic system pressure dropping below level required to meet secondary stopping requirements.

Wheel brake locks Switch activated

Parking brakes Multiple disc, spring-applied, hydraulically-released, dry brakes on inboard end of each wheel motor rotor shaft. Rated to hold on ±15% grade @ maximum gross vehicle weight.

Electric dynamic retarder Max 4026 kW **5400 hp**
 Continuous 2909 kW **3900 hp**

Continuously rated high-density blown grids w/retard at engine idle and retard in reverse propulsion.



SUSPENSION

Variable rate hydro-pneumatic with integral rebound control

Max. front stroke 328 mm **12.92"**

Max. rear stroke 239 mm **9.40"**

Max. rear axle oscillation ±6.5°

* Rear suspensions are inverted.



COOLING SYSTEM

L&M radiator assembly, split-flow, with deaeration-type top tank measuring 3277 mm x 2164 **10'9" x 7'1"**.



SERVICE CAPACITIES

Cooling System 719 L **190 U.S. gal**

Crankcase* 341 L **90 U.S. gal**

Hydraulic system 1325 L **350 U.S. gal**

Motor gear box (each) 95 L **25 U.S. gal**

Fuel 5300 L **1400 U.S. gal**

* Includes lube oil filters

 **DIMENSIONS**

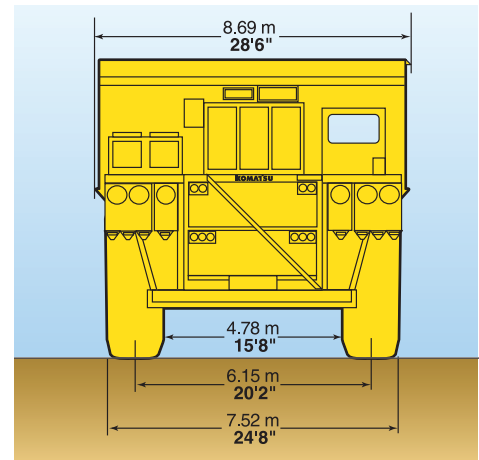
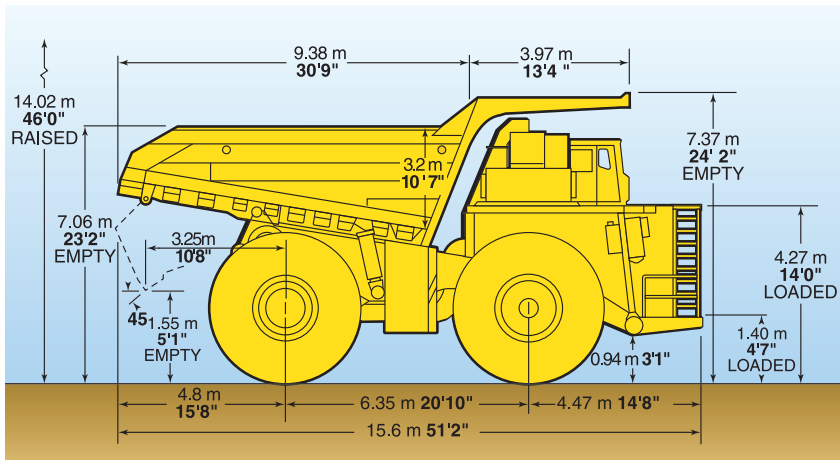

All dimensions are with 218 m³ 285 yd³ body (optional body).

Bodies	Struck	2:1 Heap	*Loading Height
Standard	171 m ³ 224 yd ³	211 m ³ 276 yd ³	7.06 m 23'2"

* Exact load height may vary due to tire make, type, and inflation pressure.

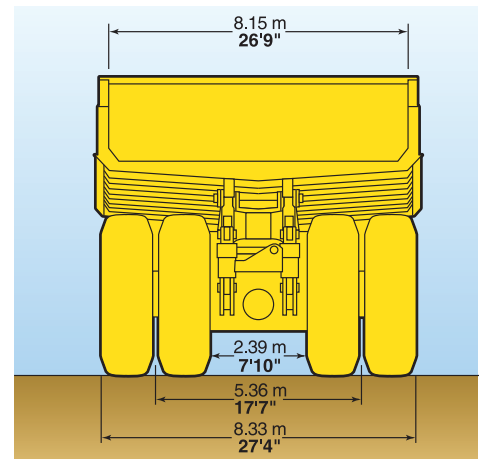

 **HYDRAULIC SYSTEM**

- Steering . . . Accumulator assisted with twin double acting cylinders provide constant rate steering. Secondary steering automatically supplied by accumulator.
- Turning circle diameter (SAE) 29.7 m 97'7"
- Reservoir 947 L 250 U.S. gal
- Filtration In-line replaceable elements
- Suction Single, full flow, 100 mesh
- Hoist and steering Dual, in-line, high pressure.
- Brake component cabinet Above deck, easily accessible with diagnostic test connections.
- Hoist Two 3-stage dual-acting outboard cylinders, internal cushion valve, over-center dampening.
- Hoist times
 - Power-up loaded 21 sec
 - Power-down 23 sec
 - Float-down empty 24 sec
- Pumps Two pumps, single package, end of alternator
- Hoist and brake cooling Tandem gear pump with output of 1022 lpm **270 gpm** at 1900 rpm and 17237 kPa **2,500 psi**
- Steering and brake Pressure-compensating axial piston pump with output of 246 lpm **65 gpm** at 1900 rpm and 18961 kPa **2,750 psi**
- System relief pressures
 - Hoist and brake cooling 17237 kPa **2,500 psi**
 - Steering and brake 27579 kPa **4,000 psi**
- Quick disconnects standard for systems diagnostics and buddy dump.

 **ELECTRICAL SYSTEM**

- 4 x 8D and 2 x 30H, 220-ampere-hour batteries, bumper-mounted with disconnect switch.
- Alternator 24 volt, 140 amp
- Lighting 24 volt
- Cranking motors two/24 volt

 **WEIGHT DISTRIBUTION**

Empty Vehicle	kg	lb	%
Front axle	104459	230,293	48.5
Rear axle	110847	244,377	51.5
Total (wet, 100% fuel)	215307	474,670	
Loaded Vehicle at maximum GVW rating			
Front axle	165956	365,871	32.8
Rear axle	339649	748,799	67.2
Total	505755	1,115,000	

NOTE: GVW shall not exceed 505755 kg **1,115,000 lb** including options, liners, fuel and payload, subject to application approval by Komatsu.

NOTE: Komatsu trucks comply with SAE specifications for cab noise, ROPS, steering and braking. Cover photos and illustrations may show optional equipment. Materials and specifications subject to change without notice.



STANDARD EQUIPMENT

- Air cleaners, Donaldson SRG
- Air filter evacuators
- Alternator (24 volt/140A)
- Auto lubrication system (Lincoln) w/ground level fill & level indicator
- Batteries—4 x 8D and 2 x 30H (1450 CCA's)
- Battery charging cable and socket
- Body over center device
- Brakes: oil-cooled, multiple disc front & rear
- Circuit breakers, 24 volt
- Control cabinet
- Electric start
- Eliminator system for engine lubrication
- Filters, high pressure hydraulic
- Gate valves on hydraulic tank
- Ground level radiator fill
- Komatsu Payload Weighing System—PLM-III
- Mirrors, LH flat and RH rectangular convex
- Mud flaps
- Muffled exhaust—deck-mounted
- Power supply, 24 volt and 12 volt DC
- Quick disconnects (hoist and diagnostics)
- Radiator sight gauge
- Removable power module unit (radiator, engine, alternator, blower)
- Retard speed control
- Reverse retarding
- Rock ejectors
- Thermostatic Fan Clutch
- Wiggins Fast-Fill Fuel System (in tank and left side remote)
- Service Center—LH
- Body Impact Plate

OPERATOR ENVIRONMENT & CONTROL:

- All hydraulic service brakes with secondary auto apply
- Battery disconnect switch
- Body up sling
- Brake lock and drive system interlock
- Circuit breakers, 24 volt
- Diagonal staircase across grille, L to R
- Dynamic retarding with continuous rated element grids
- Engine shutdown at ground level
- Hoist propulsion interlock
- Horns (electric—front and back-up)
- Integral ROPS/FOPS Cab Level 2

- Maintenance and power lockout
- Parking brakes with warning light & speed application protection
- Power steering w/auto secondary steering
- Protective deck handrails
- Pump driveline protector
- Radiator fan guard
- Seat belts 76 mm 3" retractable
- Skid-resistant coating on walkways

STANDARD HIGH VISIBILITY DELUXE CAB:

- AC Drive Interface Display
- Air cleaner vacuum gauges
- Air conditioner HFC-134A
- Alarm System warning lights (red)
 - Accumulator pre-charge
 - Brake/hydraulic oil temperature w/alarm
 - Coolant low level w/alarm
 - Drive system temperature w/alarm
 - Electric system fault w/alarm
 - Hydraulic oil level w/alarm
 - Low engine oil pressure w/alarm
 - Low brake pressure w/alarm
 - No propel/retard power w/alarm
 - Stop engine no propel w/alarm
 - Steering pressure w/alarm
- AM/FM/CD/MP3 and weather band
- Column-mounted retarder control
- Digital tachometer and speedometer
- Dome light
- Engine hourmeter, oil pressure gauge, coolant temperature gauge, hydraulic oil temperature gauge
- Engine shutdown w/"Smart Timer" delay
- Floor mat (double barrier)
- Fuel gauge in cab and on tank
- Fuel low level light and buzzer
- Gauges (w/backlight)
- Headlight switch
- Heater and defroster (heavy-duty)
- Heater switch
- High beam selector and indicator
- Horn (center of steering wheel)
- Indicator lights (amber):
 - Check engine w/alarm
 - Circuit breaker tripped
 - Coolant high temperature w/alarm
 - Drive system reset switch

- Drive system temperature w/alarm
- Dump body up
- Dynamic retarding
- Lincoln Lube
- Low Fuel
- Manual back-up lights
- Park brakes applied
- Propel system not ready
- Reduced propel system mode
- Retard at continuous level
- Retard speed control
- Service brakes
- Starter circuit
- Timed engine shutdown
- Insulation (Max R-Value)
- Operator seat, adjustable w/air suspension, lumbar support and arm rests
- Panel lighting (adjustable)
- Passenger seat
- Power windows
- Pressurized cab air system w/fan on
- Single brake/retarder pedal
- Starter key switch
- Sunvisor (adjustable)
- Tilt & telescoping steering wheel
- VHMS w/ORBCOMM
- Voltmeter (battery output)
- Windshield (tinted safety plate)
- Windshield wiper (dual) and washer (electric)

LIGHTING:

- Back-up lights—rear mount (2) halogen
- Back-up lights—R and L - deck mount (2) halogen
- Brake and retard lights on top of cab
- Clearance lights
- Control cabinet service light (LED)
- Dynamic retarding, rear (2) halogen
- Engine compartment service lights
- Fog lights (2) halogen
- Headlights (8) halogen
- Stairway lights
- Manual back-up light, switch and indicator
- Payload lights R and L (LED)
- Platform lights R, L and Center
- Stop & tail lights (2) (LED)
- Turn signals halogen
- Under-hood service lights



OPTIONAL EQUIPMENT

(Optional equipment may change operating weight).

- Body Liners*
- Fire extinguisher 9 kg **20 lb**
- Heated Body
- Hot start engine coolant (220V 2-2500W)
- Hot start engine oil (220V 2-600W)
- Hubodometer (miles or kilometers)
- Modular Mining Systems (MMS) ready
- Mufflers between frame rails
- Radiator shutters
- Service Center—RH
- Special language decals
- Suspensions, cold weather

*Available factory installed or non-installed. All other options and accessories listed are available factory installed only.

AE55778-01

©2009 Komatsu America Corp.

Printed in USA

D01(1M)C

01/09 (EV-1)

KOMATSU®